

Pump Pompe Pumpen Pompa	Pressure Pression Druck Pressione		Volume Débit Leistung Portata		RPM tours/min u.p.m. giri/min	Required Puissance Leistung Potenza		Inlet port Entrée Eingang Aspirazione	Outlet Sortie Ausgang Mandata	Weight Kg Poids Kg Gewicht Kg Peso Kg
	bar	PSI	l/min	GPM		HP	kW			
HHP25S	500	7250	25	6.6	1000	32.6	24.0	G 3/4	G 1/2	51
HHP30S	500	7250	30	7.9	1000	37	27.2	G 3/4	G 1/2	51
HHP38F	350	5075	38	10.0	1450	34.1	25.1	G 3/4	G 1/2	51

Dimensioni d'ingombro

Overall dimensions

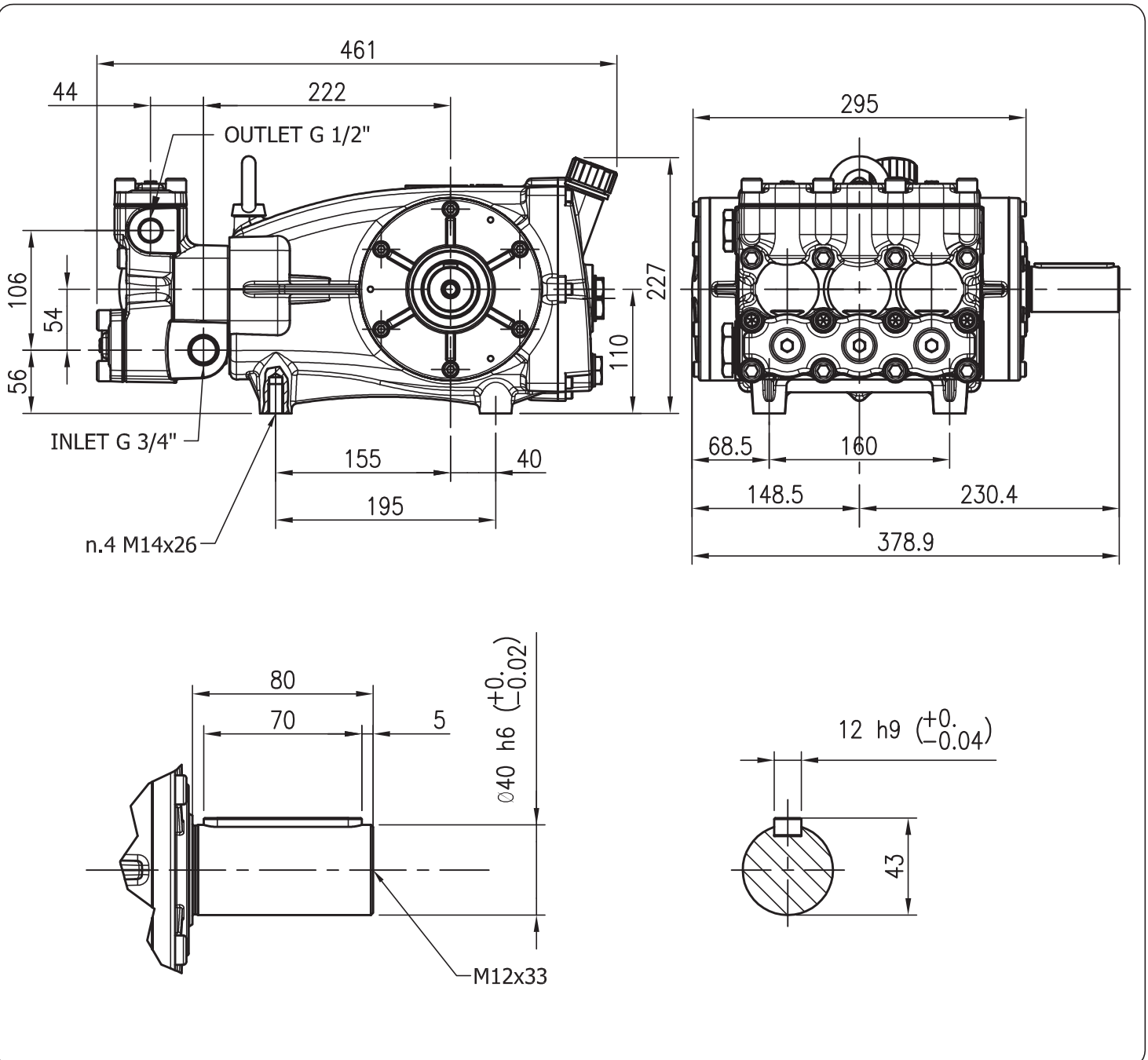

Lubrificazione: Olio SAE 10W40
Capacità 3,5 Litri

Lubrication: SAE 10W40 Oil
Capacity 3,5 Litres